

2100

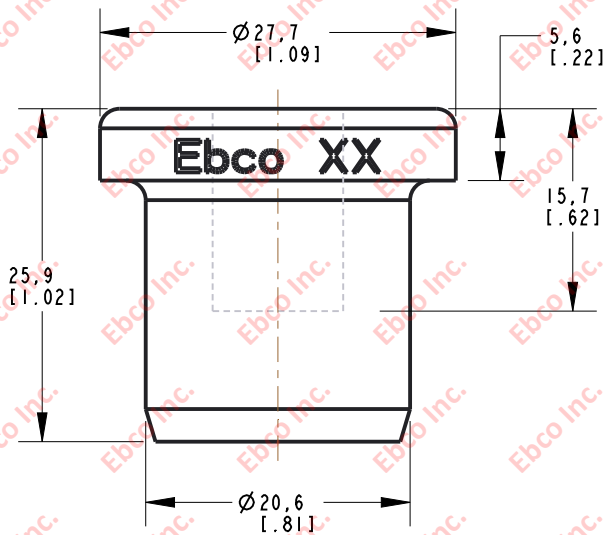

INSTALLATION VIEW (Shown under no load)

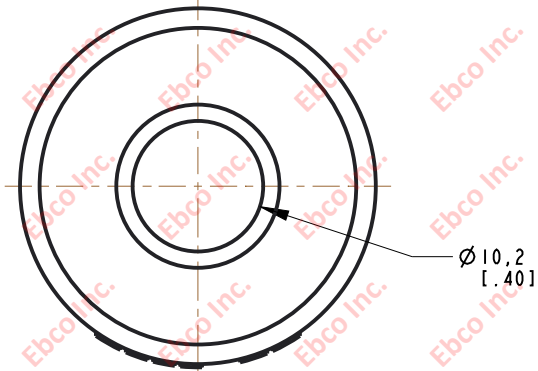
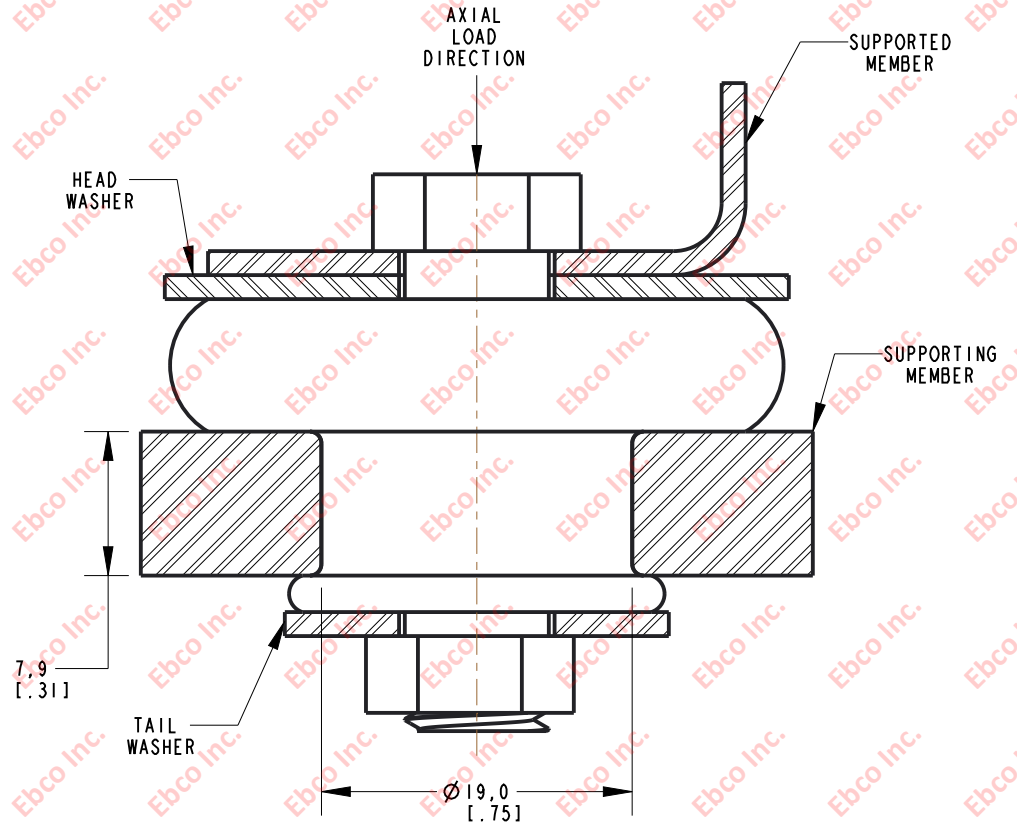

INSTALLATION DIMENSIONS

RECOMMENDED BOLT INFORMATION				TIGHTENING TORQUE			
ENGLISH		METRIC		CLAMP LOAD		TIGHTENING TORQUE	
SIZE	GRADE	SIZE	CLASS	lb	N	ft-lb	N-m
3/8	I	M10	4.6	1918	9800	12.0	19.7

WASHER SPECIFICATIONS

TYPE	O. D.		I. D.		THICKNESS	
	in	mm	in	mm	in	mm
HEAD	1.25	31.75	.40	10.16	.125	3.18
TAIL	1.12	28.45	.40	10.16		

SPECIFICATIONS

PART NUMBER		MAX. AXIAL DEFLECTION		MAX. AXIAL LOAD	
NATURAL RUBBER	NEOPRENE	in	mm	lb	N
2100-71	2100-81	.025	.635	75	334
2100-73	2100-83			100	445
2100-74	2100-84			125	556



TITLE:	2100	
THE INFORMATION CONTAINED IN THIS DRAWING IS THE SOLE PROPERTY OF EBCU ANY REPRODUCTION IN PART OR AS A WHOLE WITHOUT THE WRITTEN PERMISSION OF EBCU IS PROHIBITED.		
TOLERANCES PER RMA STANDARD	REV. E	DATE: 06-07-21
A3		UNITS: mm [INCH]
1330 HOLMES RD. ELGIN, IL 60123		

SPECIFICATIONS SUBJECT TO CHANGE