

2317A

B

A

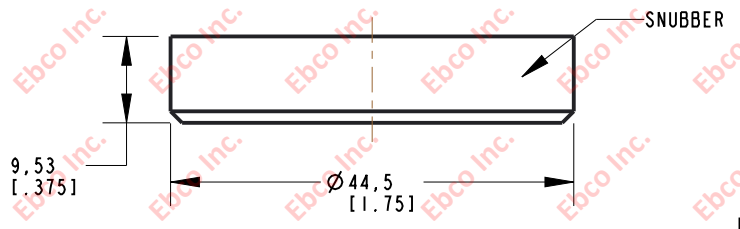
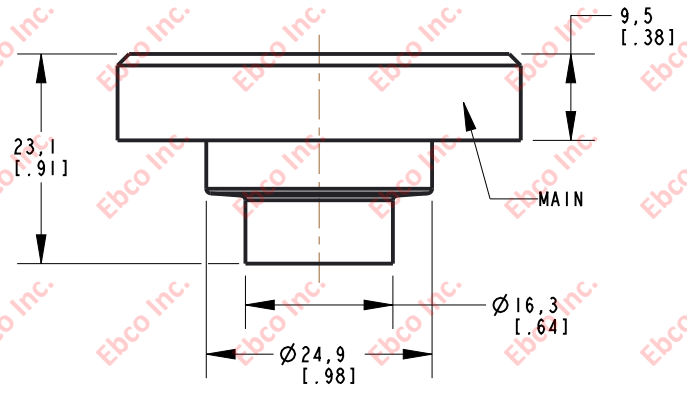
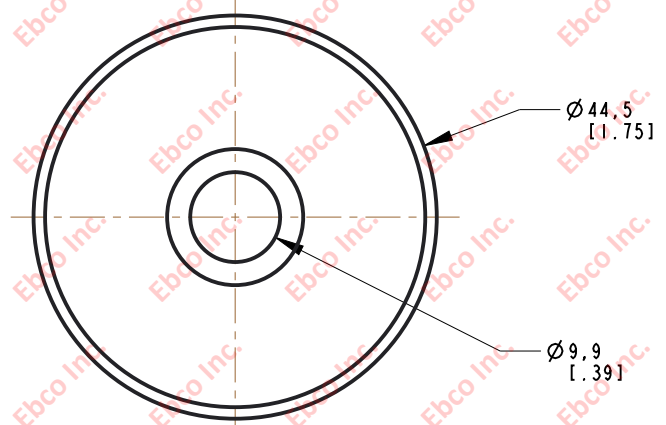

INSTALLATION VIEW (Shown under load)

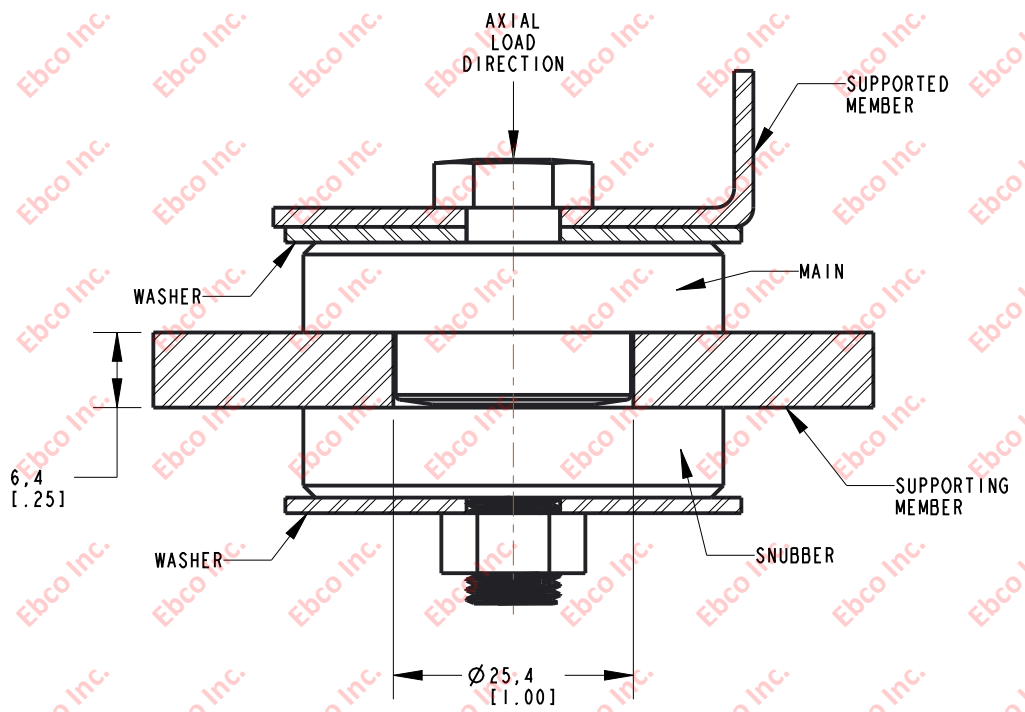

INSTALLATION DIMENSIONS

RECOMMENDED BOLT INFORMATION				TIGHTENING TORQUE			
ENGLISH		METRIC		CLAMP LOAD		TIGHTENING TORQUE	
SIZE	GRADE	SIZE	CLASS	lb	N	ft-lb	N-m
3/8	5	M8	9.8	4941	17800	30.9	28.5

WASHER SPECIFICATIONS

O.D.		I.D.		THICKNESS	
in	mm	in	mm	in	mm
2.00	50.8	.391	9.93	.125	3.18

SPECIFICATIONS

PART NUMBER		MAX. AXIAL DEFLECTION		MAX. AXIAL LOAD	
NATURAL RUBBER	NEOPRENE	in	mm	lb	N
2317A-74	2317A-84	0.04	1.02	460	2046
2317A-75	2317A-85			520	2313



TITLE: 2317A
 THE INFORMATION CONTAINED IN THIS DRAWING IS THE SOLE PROPERTY OF EBCO ANY REPRODUCTION IN PART OR AS A WHOLE WITHOUT THE WRITTEN PERMISSION OF EBCO IS PROHIBITED.
 TOLERANCES PER RMA STANDARD A3
 REV. B
 DATE: 06-09-21
 UNITS: mm [INCH]
 1330 HOLMES RD. ELGIN, IL 60123
 SPECIFICATIONS SUBJECT TO CHANGE