

2350

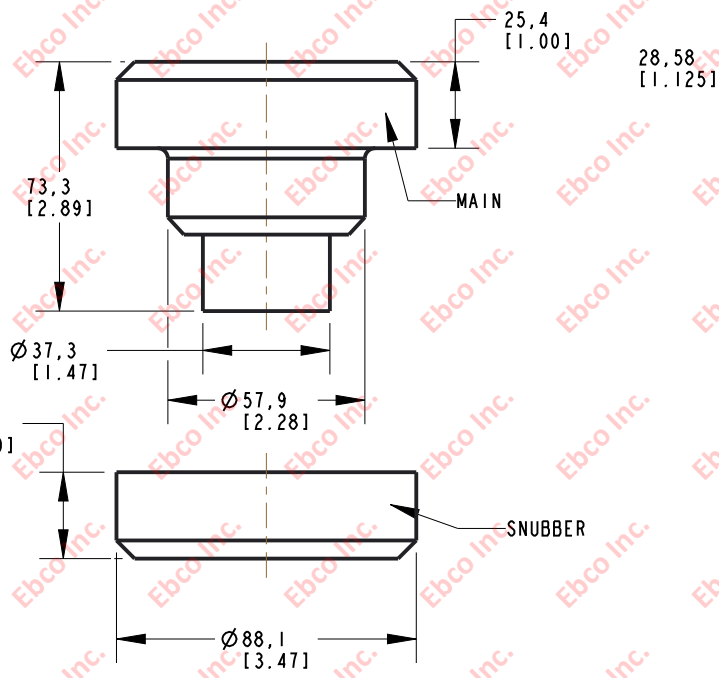

INSTALLATION VIEW (Shown under no load)

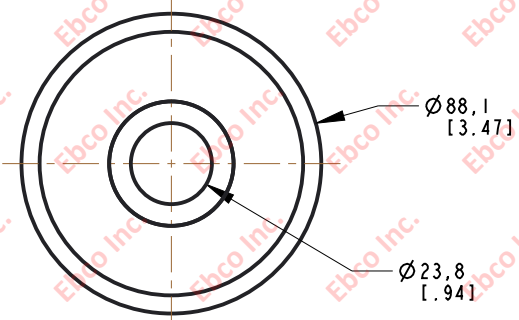
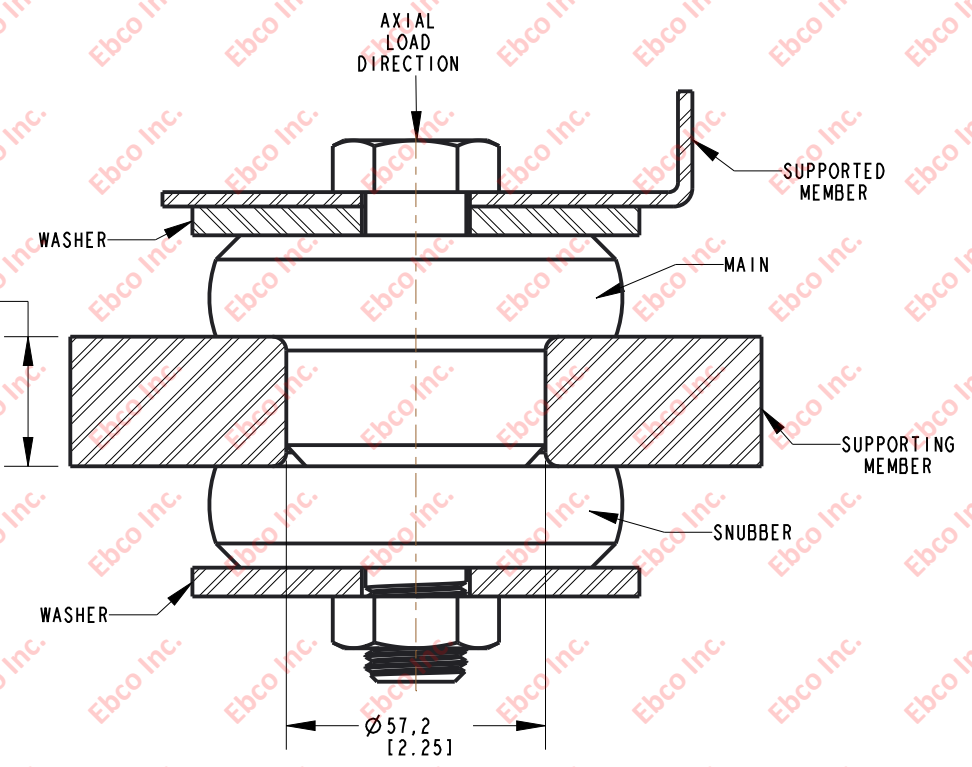

SPECIFICATIONS

PART NUMBER		MAX. AXIAL DEFLECTION		MAX. AXIAL LOAD	
NATURAL RUBBER	NEOPRENE	in	mm	lb	N
2350-71	2350-81	.10	2.54	425	1868
2350-72	2350-82			550	2447
2350-73	2350-83			700	3115
2350-74	2350-84			850	3782
2350-75	2350-85			1000	4448
2350-76	2350-86			1300	5785
2350-77	2350-87			1600	7120
2350-78	2350-88			2000	8896

INSTALLATION DIMENSIONS

RECOMMENDED BOLT INFORMATION				TIGHTENING TORQUE			
ENGLISH		METRIC		CLAMP LOAD		TIGHTENING TORQUE	
SIZE	GRADE	SIZE	CLASS	lb	N	ft-lb	N-m
7/8	5	M20	9.8	29453	131013	430	580
WASHER SPECIFICATIONS							
O. D.		I. D.		THICKNESS			
in	mm	in	mm	in	mm		
3.88	98.55	.938	23.83	.250	6.35		



TITLE: 2350
 THE INFORMATION CONTAINED IN THIS DRAWING IS THE SOLE PROPERTY OF EBCO ANY REPRODUCTION IN PART OR AS A WHOLE WITHOUT THE WRITTEN PERMISSION OF EBCO IS PROHIBITED.
 TOLERANCES PER RMA STANDARD A3
 REV. C
 DATE: 06-09-21
 UNITS: mm [INCH]
 1330 HOLMES RD. ELGIN, IL 60123

SPECIFICATIONS SUBJECT TO CHANGE